

## 58<sup>th</sup> WEEKLY NEWSLETTER

### USF INTERNAL MEDICINE & PEDIATRIC DIVISIONS OF ALLERGY AND IMMUNOLOGY

Next in the line of key historical articles of scientific impact in the medical literature is the paper on “Familial Occurrence of Asthma, Nasal Polyps, and Aspirin Intolerance” by Richard F. Lockey, MD, Distinguished University Health Professor, and Director, Division of Allergy and Immunology.

*Familial incidence of AERD and other nuances from Richard F. Lockey, MD, MS*

Aspirin Exacerbated Respiratory Disease (AERD), aspirin triad, or Sampter’s triad is reported in two families. Three members of a Mennonite family and two from another family had AERD. Two others from the same Mennonite family, one with AERD and the other with allergic asthma, were identical twins. These twins illustrate the environmental influence to develop different phenotypes of asthma, one AERD and the other allergic asthma.

An interesting thing is that the asthma in a non-triad non-allergic asthmatic male was controlled by aspirin in a double-blind challenge with aspirin 300 mg qid (see Figure 3). Asthma, a complex and varied disease.

This article appeared in the *Annals of Internal Medicine* in 1973. I presented the abstract at one of the first AAAAI meetings I attended in 1991.

With warm regards,

Richard F. Lockey, MD  
Distinguished University Health Professor  
Joy McCann Culverhouse Chair in Allergy  
and Immunology  
Professor of Medicine, Pediatrics & Public Health  
Director, Division of Allergy and Immunology  
Department of Internal Medicine

Jolan Walter, MD, PhD  
Robert A. Good Endowed Chair in Immunology  
Associate Professor of Pediatrics and Medicine  
Chief, Division of Allergy and Immunology  
Department of Pediatrics

# Familial Occurrence of Asthma, Nasal Polyps, and Aspirin Intolerance

RICHARD F. LOCKEY, M.D., DONALD L. RUCKNAGEL, M.D., Ph.D., and  
NEAL A. VANSELOW, M.D., F.A.C.P., Ann Arbor, Michigan

Four members of a Mennonite family, three of whom were first cousins, had asthma, nasal polyps, and aspirin-induced wheezing (ASA triad). One of the cousins, whose husband was also a member of the isolate, had a daughter with the ASA triad and an identical twin sister with allergic rhinitis and extrinsic asthma. The twin with the ASA triad and her husband shared common ancestors in the eighth ancestral generation. Two siblings of a non-Mennonite family also had the ASA triad. A third sibling had intrinsic asthma alone, which improved after the ingestion of aspirin. We are aware of only one previous report of the ASA triad in families. The presence of the ASA triad in these constellations of relatives suggests that it is inherited as an autosomal recessive trait. The discordance in the identical twins suggests that the phenotype is also influenced by environment.

**W**HEEZING after the ingestion of aspirin has been reported to occur in 2% to 10% of asthmatic patients (1-6). In such individuals, severe and sometimes life-threatening bronchospasm will occur within from minutes to 2 hours after ingestion of as little as 300 mg of the drug. In some patients the bronchospasm may be accompanied by profuse rhinorrhea, flushing, pruritis, urticaria, hypotension, and loss of consciousness (6).

Most asthmatic patients manifesting this sensitivity also experience wheezing at times when no aspirin has been ingested. Their asthma is usually perennial—without obvious seasonal variation—is precipitated by upper respiratory infections and nonspecific physical factors, rather than by exposure to known inhalants or food allergens, and is associated with

negative allergy skin tests and normal serum IgE levels. These features are characteristic of the "intrinsic" or "nonallergic" type of asthma, rather than "extrinsic" or "allergic" asthma. The latter is usually characterized by seasonal variation, a history of exacerbation on exposure to known allergens, positive allergy skin tests, and elevated serum IgE levels.

Most aspirin-sensitive asthmatics also have a perennial form of nonallergic vasomotor rhinitis and nasal polyps (1, 5-9). The constellation of intrinsic asthma, aspirin intolerance, and nasal polyps has been referred to by some as the "ASA triad" (10, 11).

The acetyl group appears to be causally important in aspirin intolerance since other salicylates can be ingested with impunity (8, 12, 13). For unknown reasons, some aspirin-intolerant individuals also develop wheezing after the ingestion of indomethacin, mefenamic acid, aminopyrine, and tartrazine (8, 14-16).

There have been numerous unsuccessful attempts to show that aspirin-induced wheezing is immunologic in origin (6, 17-21). In recent years several non-immunologic mechanisms for the ASA triad have been proposed. Samter and Beers (8, 14) feel that aspirin may stimulate rather than block kinin receptors in affected individuals, causing symptoms produced by kinins in the lung and other tissues. Yurchak, Wicher, and Arbesman (19) have suggested two other mechanisms. First, aspirin may cause an abnormal activation of the complement cascade. Second, the lack of an enzyme inhibitor may permit aspirin to activate tissue enzymes, causing tissue damage and release of chemical mediators. Since there is little solid scientific evidence to support any of these theories, the mechanism of aspirin-induced asthma remains unknown.

In this paper we will describe the occurrence of

► From the Departments of Internal Medicine and Human Genetics, University of Michigan Medical Center, Ann Arbor, Mich.

the ASA triad in two genetically unrelated families. To the best of our knowledge, familial occurrence of the ASA triad has been reported by only one other investigator (22). Although the dangers of aspirin administration to such persons precluded actual aspirin challenge, all the affected individuals in our series had both the classic history and typical physical findings of the ASA triad.

### Materials and Methods

Prick and intradermal skin tests to a routine battery of over 120 food and inhalant allergens were done at the University of Michigan Medical Center, Ann Arbor, Mich.; previously described allergen concentrations and testing techniques were used (23). No medications except corticosteroids were permitted for the 12 hours prior to skin testing. Blood specimens obtained from the twins and their parents were genotyped for zygosity, with use of a panel of eighteen blood group antisera. In addition, starch gel electrophoresis of serum was performed for haptoglobin and group specific component (24, 25). Red cell lysates were also electrophoresed, by standard techniques (26), for phosphoglucomutase, acid phosphatase, 6-phosphogluconate dehydrogenase, and adenylate kinase.

Serum IgE levels were measured by Dr. Richard Newcomb at the Children's Asthma Research Institute in Denver, Colo., by use of the radioimmunoassay method (27, 28). Normal serum IgE values for adults at that institution range from 20 to 450 ng/ml, with a mean of 143 ng/ml; chronic corticosteroid therapy slightly lowers IgE levels (28).

### Case Reports and Family Histories

#### FAMILY A

Family A (Figure 1) is a Mennonite family consisting of over 200 members, many of whom live in

the "Thumb" area of eastern Michigan. The Mennonites are a religious sect, related to the Amish, with origins in Western Europe (29). Because of their religion they are somewhat isolated from the rest of the population, which has resulted in many cases of intermarriage.

Ancestors of Family A settled in Michigan more than 100 years ago, and many of the progeny have remained in the Thumb area. Other than agricultural occupations, there are no other identifiable environmental features that are unique to this family. Four members of Family A, including three first cousins who were offspring of different parents, and a daughter of one of the cousins had the ASA triad. No other members of preceding generations were known to have intrinsic asthma, aspirin intolerance, or nasal polyps, according to information obtained from members of those generations or from family historians.

*Case A1:* Patient Marjorie M., the proposita, is a 48-year-old white woman who has been followed in The University of Michigan Allergy Clinic for 8 years. Twenty-five years ago she noted the insidious onset of wheezing, and she developed nasal polyps. Since onset, her asthmatic symptoms have been perennial—unrelated to season or specific allergenic exposure—and exacerbated by upper respiratory infections. On several occasions aspirin ingestion has induced rhinitis, urticaria, and severe asthma within an hour. She has never smoked and has lived on a farm her entire life.

Physical examination has been unremarkable, except for nasal polyps and wheezing on auscultation of the chest. Her chest X ray is normal, but sinus films have shown diffuse clouding of all sinuses. All scratch and intradermal tests to food and inhalant allergens are

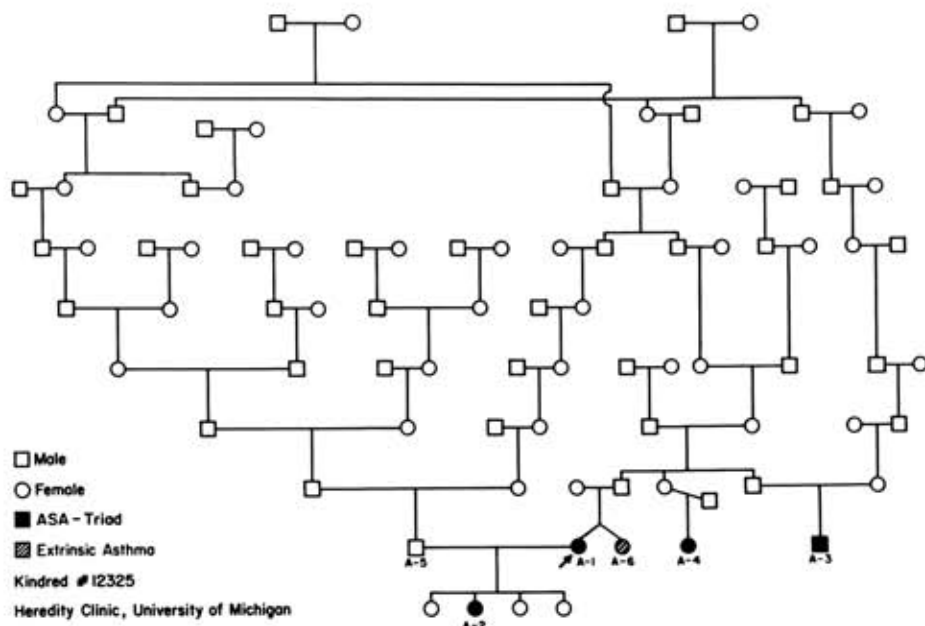

Figure 1. Pedigree of Family A.

negative. She has been treated with oral bronchodilators, intermittent antibiotics, expectorants, and maintenance corticosteroids, and has required several hospitalizations for control of her asthma.

**Case A2:** Patient R.M., the 23-year-old daughter of the proposita, has been followed at The University of Michigan Allergy Clinic for 4 years. Approximately 5 years ago she noted the onset of perennial nasal stuffiness and intermittent yellow nasal discharge. Six months later she developed nasal obstruction, sneezing, rhinorrhea, and wheezing for 30 minutes after aspirin ingestion. These symptoms recurred on several occasions after ingestion of aspirin or aspirin-containing compounds. There is no history of wheezing at other times. Her allergy environmental survey is negative. Physical examination was negative, except for the presence of a large nasal polyp on the right. Allergy skin tests were negative. Forced expiratory volume in 1 second (FEV<sub>1</sub>) was 3.2 litres with a forced vital capacity (FVC) of 3.5 litres. The patient was treated with oral antihistamines and was advised to avoid aspirin and aspirin-containing drugs.

**Case A3:** E.S., a first cousin of the proposita, is a 50-year-old white man with a 6-year history of perennial asthma. Nasal polyps were first noted 4 years ago. At the same time, he noted that aspirin ingestion caused a severe exacerbation of his asthma. Aspirin-containing compounds were ingested unknowingly on several occasions, resulting in severe wheezing in 30 minutes. The patient is a nonsmoker. Physical examination has been negative, except for nasal polyps and audible wheezing and rhonchi. A Chest X ray was normal. Skin tests, done by Dr. Paul Seebom at the University of Iowa, Iowa City, Iowa, were negative except for a moderate intradermal reaction to house dust. The patient gives no history of house dust sensitivity. Hyposensitization to dust has been ineffective, and the patient has been maintained on oral corticosteroids.

**Case A4:** D.K., another first cousin of the proposita, is a 53-year-old white woman who first noted the onset of intermittent clear rhinorrhea and nasal congestion 18 years ago. The nasal symptoms were perennial and questionably exacerbated by house-dust exposure. Approximately 2 years later, she noted severe wheezing 15 to 20 minutes after ingesting aspirin. Her asthma has since become perennial and has been exacerbated by weather changes, cold air, and upper respiratory infections, in addition to aspirin. Although she has had nasal polypectomies, neither nasal polyps nor wheezing were demonstrable when she was examined during this study. The remainder of her physical examination was also unremarkable. Numerous prick and intradermal skin tests were negative. The patient's family physician has treated her with oral bronchodilators, corticosteroids, and intermittent antibiotics.

**Case A5:** A.M., the husband of the proposita, is a 52-year-old white man who gives no history of asthma, nasal polyps, or aspirin intolerance. He is a member of the Mennonite isolate. Although close consanguinity with his wife could not be established, they share common ancestors in the eighth ancestral generation (Figure 1). Additional consanguinity in more proximal generations cannot be excluded.

**Case A6:** Patient Marie M., a twin sister of the proposita, is a 48-year-old white woman. She also lives

on a farm and has a history of seasonal allergic rhinitis, present since childhood. She has noted exacerbations of her rhinitis during the spring and fall and on exposure to house dust. She has had asthma since the age of 16, which is exacerbated by exposure to house dust. She can ingest aspirin with impunity, has never smoked, and gives no history of nasal polyps. A physical examination done for this study was negative, except for mild pallor and edema of the nasal mucosa. Her chest was clear to auscultation.

Prick tests showed 2 to 4+ positive reactions to various weeds, house dust, and feathers. Intradermal skin tests were 2 to 4+ positive to tree pollen, grass pollen, animal danders, and molds. The FEV<sub>1</sub> was 1.9 litres with a FVC of 3.0 litres. The patient has been treated by her physician with oral bronchodilators and intermittent oral corticosteroids.

The twins' genotypes were concordant at all of the fifteen genetic loci tested. Their parents' genotypes were different at seven loci. The probability that the twins are dizygotic rather than identical is only 0.0038 according to the computational method of Race and Sanger (30).

Ninety-three of more than 200 other members of Family A were interviewed and briefly examined. None gave histories of nasal polyps or aspirin intolerance. Five percent of the 93 had definite histories of allergic rhinitis. Thirty-eight percent gave vague histories of rhinitis, wheezing, or eczematoid skin rashes, but a diagnosis of asthma, allergic rhinitis, or atopic eczema could not be made. Fifty-seven percent had no history of asthma, rhinitis, or eczema.

#### FAMILY B

The propositus of Family B (Figure 2) has four siblings; one has the ASA-triad and another has intrinsic asthma that is relieved by aspirin. Two other

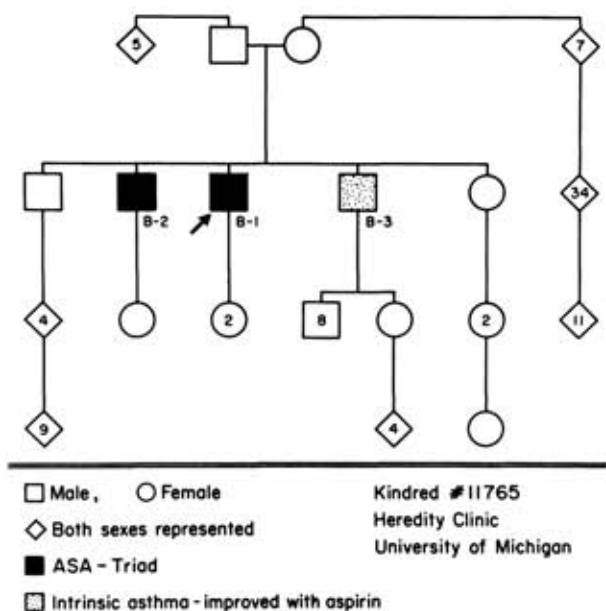

Figure 2. Pedigree of Family B.



siblings are unaffected. The parents and grandparents of the affected generation, all of whom are dead, are of Belgian extraction. According to the propositus and his siblings, none of them had asthma, aspirin intolerance, or nasal polyps. There is no family history of atopy. There are no identifiable environmental characteristics that are peculiar to this family. Until recently all the siblings have lived in lower Michigan.

**Case B1:** J.V., the propositus, is a 56-year-old white man, a cabinet-maker, who has been followed in The University of Michigan Allergy Clinic for 6 years. Perennial clear rhinorrhea and nasal congestion began 9 years ago. One year later he noted the onset of perennial wheezing, which persisted without any seasonal variation. He was treated with bronchodilators, hypsensitization, and an elimination diet by his allergist without any improvement. Six years ago he was found to have nasal polyps, which necessitated a polypectomy. Seven years ago he noted that aspirin ingestion caused a severe immediate exacerbation of his asthma; subsequently, this occurred on several occasions. He has never smoked.

He was first seen at The University of Michigan Medical Center in June 1965, at which time nasal polyps and wheezing were noted. Allergy skin tests were negative to both food and inhalant allergens. A chest X ray was normal, but sinus films showed pansinusitis. A complete blood count was normal, except for peripheral blood eosinophilia of 19%. Since 1965 he has done well on oral bronchodilators and nebulized dexamethasone, although nasal obstruction by polyps necessitated a nasal polypectomy in April 1971.

**Case B2:** Patient M.V., a brother of the propositus, is a 59-year-old man who was seen once during this study. He has had perennial asthma since age 45. Wheezing has been exacerbated by upper respiratory infections but never by exposure to specific allergens. In 1960 he was found to have nasal polyps and has undergone several nasal polypectomies since then. One year after the onset of asthma he noted that aspirin ingestion caused severe dyspnea within 20 minutes. This has recurred on several occasions with the accidental ingestion of aspirin-containing medications. His past medical history was otherwise unremarkable. There is no history of smoking.

A physical examination showed bilateral nasal polyps and scattered wheezes on auscultation of his lungs but was otherwise unremarkable. Numerous scratch and intradermal skin tests were negative. A chest X ray was normal. The patient's asthma is presently controlled with oral prednisone and nebulized bronchodilators.

**Case B3:** Patient A.V., a 52-year-old brother of the propositus, developed wheezing after an upper respiratory infection 11 years ago. Mild asthma has persisted perennially since that time. Respiratory symptoms have never been exacerbated by seasonal changes or specific allergic exposure. He has no history of rhinitis or nasal polyps. Aspirin ingestion improves his asthma for 24 to 48 hours, which permits him to temporarily stop his regular use of oral bronchodilators. His past medical history is unremarkable. He has a five pack-year history of cigarette smoking but has not smoked for the last 20 years.

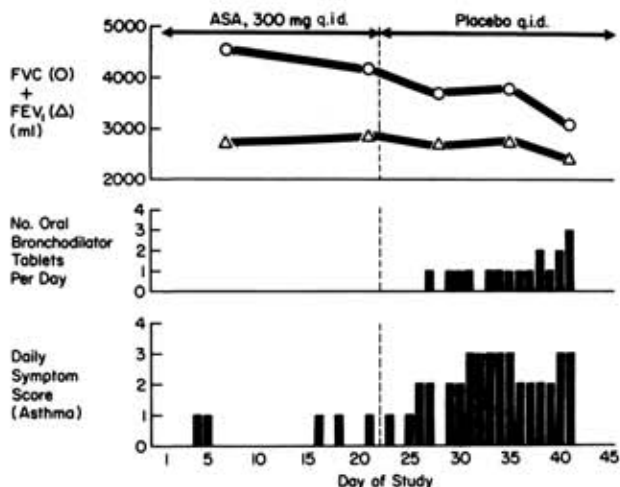

**Figure 3.** Double-blind study with aspirin (ASA) and placebo in Patient A.V. Daily subjective asthma was graded by the patient on a 0 to 5 scale, with 1+ representing barely discernible wheezing and 5+ representing acute asthma requiring parenteral epinephrine or aminophylline. FVC = forced vital capacity; FEV<sub>1</sub> = forced expiratory volume in 1 second.

His physical examination was completely within normal limits except for wheezing, which was heard on various occasions. Skin tests were negative except for a 3+ positive intradermal skin test to house dust. A chest X ray showed only tortuosity of the aorta. The FEV<sub>1</sub> was 2.7 litres and the FVC, 3.7 litres.

To see if aspirin did relieve his bronchospasm, a double-blind study was done with aspirin capsules and an identical-appearing placebo. During this 6-week study, the patient graded his subjective asthma daily on a 0 to 5 scale, with 1+ representing barely discernible subjective wheezing and 5+ representing acute asthma requiring parenteral epinephrine or aminophylline. He also noted the number of oral bronchodilator tablets that were required daily for control of his symptoms. He was seen and examined at 1- to 2-week intervals throughout the study. As seen in Figure 3, he required few bronchodilators during the 3 weeks of aspirin administration (300 mg four times daily). During this period he noted very mild wheezing or chest tightness on only five occasions. In contrast, while on the placebo, he required frequent oral bronchodilators and noted almost daily asthma of a mild to moderate severity, which strongly suggests that the effect of aspirin in Patient A.V. was exactly opposite to that noted by two of his brothers.

## Discussion

These data suggest that the ASA triad can be familial. The clinical history and physical findings in the six patients described in this paper are no different from those nonfamilial cases reported in other studies (1-3, 5, 12). With the exception of Patient R.M. (Case A2), their symptoms began during middle age. All had rhinitis, nasal polyps, and intrinsic asthma, with negative allergy histories and skin tests. Because of the severity of the asthma, five of the six

required regular or intermittent corticosteroids for treatment of their bronchospasm.

Serum IgE levels (Table 1) in this group of patients were similar to those described in other patients with the ASA triad (31). With the exception of Patient M.V. (Case B2), all the aspirin-intolerant patients had normal IgE values. The reason for the elevated level in Patient M.V. is unknown. As expected, Patient Marie M. (Case A6), the identical twin sister with allergic rhinitis and mixed asthma, had a high normal serum level of IgE.

The mode of inheritance of this syndrome defies a simple explanation. Since the triad is relatively rare, it is not likely that these familial aggregates can be explained by chance alone.

Parent to offspring transmission (A1 to A2) suggests an autosomal dominant mode of inheritance. But, if so, the degree of penetrance is very low, since the parents of offspring A1, A3, A4, and the affected individuals of family B are unaffected. This seems to be an unlikely explanation.

In both families the most likely interpretation is that this is an inherited autosomal recessive trait; the affected individuals are presumably homozygotes. We have not been able, as yet, to show closer inbreeding. The twin (Case A1) and her husband shared a pair of common ancestors in the eighth ancestral generation through five different lines of descent. Nevertheless, their affected daughter's inbreeding coefficient, the odds that she would be homozygous for a gene present in a common ancestor, is only 0.0002. The inbreeding coefficient for individual A3 is 0.00049. Individuals A1 and A4 are presumably not inbred, since common ancestors for their parents cannot be identified.

These small inbreeding coefficients indicate that consanguinity alone is not a factor in the disease in this family. The Mennonites are a genetic isolate, however, and so may show the so-called founder effect (32); that is, if a population has been derived from a small number of founders, by chance alone gene frequencies in the founder group may be very different from those of the ethnic group from which the founders were derived. Thus, the current generation of the isolate could possess in high frequency genes that are ordinarily rare. Even without close inbreeding, isolated populations have proved to be a rich source of recessively inherited diseases (33).

On the other hand, a strictly genetic interpretation is at odds with the discordance in clinical manifestations in the identical twins. Discordance in the clinical manifestations of atopic disease in identical twin siblings has previously been reported by others (34-37). Also, in family B in this report, a simple genetic mechanism responsible for the presence of the ASA triad in siblings would require that all of the affected siblings have the same response to aspirin ingestion. A possible explanation is that the underlying genetic mechanism can also be influenced by environmental factors. This interpretation is supported by the relatively advanced age at which most patients develop the ASA triad.

It is difficult to delineate the hypothetical environmental factor. The fact that the cousin of family A residing in Iowa has had no contact with his relatives in Michigan suggests that the environmental stimulus may be ubiquitous. A combined genetic and environmental cause is also consistent with a possible immunologic mechanism. Nevertheless, as previously noted, much experimental work has failed to demon-

Table 1. Clinical Data on Family A and Family B

Patient	Case	Age	Sex	Type of Asthma	Nasal Polyps	Response to Aspirin	Allergy Skin Tests	Steroid Therapy	Serum IgE Level
		<i>yr</i>							<i>ng/ml</i>
Marjorie M.	A1	48	F	Intrinsic	Present	Wheezing	Negative	Betamethasone, 0.6-1.2 mg daily	125
R.M.	A2	23	F	Intrinsic	Present	Wheezing	Negative	No	125
E.S.	A3	50	M	Intrinsic	Present	Wheezing	Positive only to house dust	Prednisone, 10 mg daily	145
D.K.	A4	53	F	Intrinsic	Present	Wheezing	Negative	Methylprednisolone, 4 mg daily	165
A.M.	A5	52	M	None	None	Not abnormal	Negative	No	—
Marie M.	A6	48	F	Extrinsic	None	Not abnormal	Positive	Betamethasone, 0.6-1.2 mg daily, p.r.n. for severe asthma	425
J.V.	B1	56	M	Intrinsic	Present	Wheezing	Negative	Dexamethasone by bronchial aerosol, 4-12 inhalations daily	145
M.V.	B2	59	M	Intrinsic	Present	Wheezing	Negative	Prednisone, 2.5 mg every other day	520
A.V.	B3	52	M	Intrinsic	None	Asthma improved	Positive only to house dust	No	125

strate that immunologic factors are etiologically involved in the ASA triad.

Several additional observations merit comment. First, the discordant clinical manifestations in the monozygotic twins in family A does raise the question of whether the basic abnormalities in intrinsic asthma, on the one hand, and extrinsic asthma and allergic rhinitis, on the other, are as different as presently theorized (8, 14, 19). Second, in Patient A.V. (Case B3) of family B, the ingestion of aspirin produced relief of asthma. This phenomenon has been previously reported by Cooke (38), but it is believed to be rare. The underlying mechanism is not clear. It is particularly interesting in this case since two of individual B3's siblings, B1 and B2, have aspirin-induced asthma. These findings make it tempting to speculate on the abnormal receptor theory suggested by Samter and Beers (8, 14). Since one action of aspirin is to block kinin receptors, it is conceivable that in the case of sibling B3, receptor blockade in the lung is enhanced by aspirin to an unusual degree, preventing bronchospasm (39). In his aspirin-intolerant brothers, stimulation of the same receptor might occur, thereby producing bronchospasm. It is conceivable that a minor epigenetic alteration in the receptor could account for the discordant responses in both families.

We have outlined the occurrence of the ASA triad in multiple members of two genetically unrelated families. These data suggest that in some instances genetic factors may be causally involved in this syndrome, the distribution of the trait suggesting autosomal recessive inheritance. Other features, namely, the presence of extrinsic asthma in an identical twin and the relief of asthma by aspirin in a sibling of individuals with the ASA triad, suggest that environmental factors may also be operative. The data emphasize the need for additional studies of the role of heredity in what is now a disease of unknown cause.

**ACKNOWLEDGMENTS:** The authors are grateful to Drs. James V. Neel and Henry Gershowitz for assistance in the twin genotyping; to Mrs. Grace Y. Sundling of the Heredity Clinic and Dr. Delbert Gratz of the Mennonite Historical Library, Bluffton, Ohio, for assistance in tracing the genealogy; and to Dr. Paul Seebohm, University of Iowa Medical School, Iowa City, Iowa, for supplying the information on Case A3.

Supported by U.S. Public Health Service grant 5T01-AI-00044-14 from the National Institute of Allergy and Infectious Diseases, Bethesda, Md.

Presented in part at the 27th annual meeting of the American Academy of Allergy, 24 February 1971, Chicago, Ill.

Received 23 June 1972; revision accepted 29 September 1972.

► Requests for reprints should be addressed to Neal A. Vanselow, M.D., Chairman, Department of Postgraduate Medicine and Health, Professions Education, University of Michigan Medical School, Ann Arbor, Mich. 48104.

## References

1. WALTON CHA, BOTTOMLEY HW: Allergy to aspirin. *Can Med Assoc J* 64:187-190, 1951
2. WALTON CHA, RANDLE DL: Aspirin allergy. *Can Med Assoc J* 76:1016-1018, 1957
3. PEARSON RSB: Hypersensitivity to aspirin, in *Salicylates, an International Symposium*, edited by DIXON ASJ, MARTIN KB. London, J. & A. Churchill, Ltd., 1963, p. 170
4. TAINTER ML, FERRIS AJ: *Aspirin in Modern Therapy*. New York, Bayer Company Division of Sterling Drug, Inc., 1969, pp. 90-91
5. GARDNER E, BLANTON WB: The incidence of aspirin hypersensitivity. *Am J Med Sci* 200:390-394, 1940
6. GIRALDO B, BLUMENTHAL MN, SPINK WW: Aspirin intolerance and asthma. *Ann Intern Med* 71:479-496, 1969
7. FRIEDLAENDER S, FEINBERG SM: Aspirin allergy: its relationship to chronic intractable asthma. *Ann Intern Med* 26:734-740, 1947
8. SAMTER M, BEERS RF: Intolerance to aspirin. Clinical studies and considerations of its pathogenesis. *Ann Intern Med* 68:975-983, 1968
9. SALÉN EB, ARNER B: Some views on the aspirin-hypersensitive allergy group. *Acta Allergol (Kbh)* 1:47-84, 1948
10. SNYDER RD, SIEGAL GL: An asthma triad. *Ann Allergy* 25:377-380, 1967
11. PRICKMAN LE, MORGAN JL: Intolerance to common drugs in asthma—a clinic. *Med Clin N Am* 31:954-961, 1947
12. PRICKMAN LE, BUCHSTEIN HF: Hypersensitivity to acetylsalicylic acid (aspirin). *JAMA* 108:445-451, 1937
13. COOKE RA: Allergy in drug idiosyncrasy. *JAMA* 73:759-760, 1915
14. SAMTER M, BEERS RF: Concerning the nature of intolerance to aspirin. *J Allergy* 40:281-293, 1967
15. VANSELOW NA, SMITH JR: Bronchial asthma induced by indomethacin. *Ann Intern Med* 66:568-572, 1967
16. SAMTER M: Bronchial asthma induced by mefenamic acid. Unpublished
17. HANSEN-PRUSS OC: Studies of drug sensitivity. *Ann Allergy* 7:219-227, 1949
18. MATHEWS KP, LOVELL RG, SHELDON JM: The problems of aspirin allergy with a report of skin testing with salicylate containing human serum. *J Lab Clin Med* 36:416-421, 1950
19. YURCHAK AM, WICHER K, ARBESMAN CE: Immunologic studies on aspirin. Clinical studies with aspirin-protein conjugates. *J Allergy* 46:245-253, 1970
20. GIRARD JP, HILDEBRANDT F, FAVRE H: Hypersensitivity to aspirin: clinical and immunological studies. *Helv Med Acta* 35:86-95, 1969/70
21. FEINBERG AR, MALKIEL S: Aspirin sensitivity-experimental studies. *J Allergy* 22:74-81, 1951
22. MILLER FF: Aspirin-induced bronchial asthma in sisters. *Ann Allergy* 29:263-265, 1971
23. VANSELOW NA: Skin testing and other diagnostic procedures, in *A Manual of Clinical Allergy*, edited by SHELDON JM, LOVELL RG, MATHEWS KP. Philadelphia, W. B. Saunders Co., 1967, pp. 55-77
24. GAHNE B: Studies of transferrins in serum and milk of Swedish cattle. *Animal Products* 3:135-145, 1961
25. SMITHIES O: Characterization of genetic variants of blood proteins. *Vox Sang* 10:359-362, 1965
26. BREWER GJ: *An Introduction to Isozyme Techniques*. New York, Academic Press, 1970, p. 186
27. LICHTENSTEIN LM, LEVY DA, ISHIZAKA K: In vitro reversed anaphylaxis: characteristics of anti-IgE mediated histamine release. *Immunology* 19:831-842, 1970
28. KUMER L, NEWCOMB RW, ISHIZAKA K, et al: IgE levels in sera of children with asthma. *Pediatrics* 47:848-856, 1971
29. AURAND AM: *Little Known Facts About the Amish and the Mennonites*. Harrisburg, Pa., The Aurand Press, 1938
30. RACE RR, SANGER R: *Blood Groups in Man*. Philadelphia, F. A. Davis Co., 1962, pp. 368-384
31. HENDERSON LL, SWEDLUND HA, VAN DELLEN RG, et al: Evaluation of IgE tests in an allergy practice. *J Allergy Clin Immunol* 47:361-365, 1971
32. MAYR E: *Systematics and the Origin of Species*. New York, Columbia University Press, 1970, p. 186
33. MCKUSICK VA, HOSTETLER JA, EGELAND JA, et al: The distribution of certain genes in the Old Order Amish. *Cold Spring Harbor Symp Quant Biol* 29:99-114, 1964

34. CRIEP LH: Allergy in identical twins. *J Allergy* 13:591-598, 1942
35. BUFFUM WP, FEINBERG B: Bronchial asthma in three pairs of identical twins. *J Allergy* 11:604-606, 1940
36. BOWEN R: Allergy in identical twins. *J Allergy* 26:236-244, 1953
37. FALLIERS CJ, CARDOSO RR, BANE HN, et al: Discordant allergic manifestations in monozygotic twins: genetic identity versus clinical, physiologic, and biochemical differences. *J Allergy* 47:207-219, 1971
38. COOKE RA: *Allergy in Theory and Practice*. Philadelphia, W. B. Saunders Co., 1947, p. 146
39. COLLIER HOJ: New light on how aspirin works. *Nature (Lond)* 223:35-37, 1969



## Distance Between the Doctor and the Patient

THE FOCUS on specific disease processes also enables the physician to deny the devastating effect a disease may have on the quality of his patient's life. The medical student early in his career often raises questions about prolonging a patient's life despite the patient's unremitting misery. He also questions the physician's reluctance to allow both patient and family to participate in crucial treatment decisions. These issues seem gradually to become dormant by the time the medical student is a house officer; the student is rarely aware of his attempt to rationalize and deny his feelings. This occurs because of the pressure to identify with the models provided by the various medical mentors available. These teachers are often struggling with the same issues and perpetuate a mode of interaction and thinking which may not consider total patient care.

In many ways our system of medical education has turned the dehumanization of patients into an institutionalized phenomenon. Kaufman and his colleagues observed that patients were frequently upset when rounds were conducted at the bedside and the patient was talked "about" rather than talked "with"; patients also reacted very negatively to the violation of privacy in examinations, the berating of house staff by attending physicians, and the use of jargon which often left the patient in a state of uncertainty and anxiety. They suggest that bedside rounds be limited to the observation and examination of patients while detailed discussion be conducted out of their earshot.

Another aspect of dehumanization and denial is observable in the use of humor. It is effective in relieving tension but is often inappropriate in its intensity and pervasiveness. The most somber and even pathetic scenes can evoke humor. This serves to increase the distance between doctor and patient by preventing the doctor from confronting the realities of his patient's plight.

ELLEN L. BASSUK and CAROL C. NADELSON  
A dilemma in medical education.  
*Journal of Medical Education* 47:894-900, 1972